

- 1
- 2
- 3
- 4
- 5
- 6
- 7
- 8
- 9
- 10
- 11
- 12
- 13
- 14
- 15
- 16
- 17
- 18

**MATERIAL**

Cast aluminium, fine sandblasted matte surface, turned and mirror-polished rim.

**STANDARD EXECUTION**

H7 reamed hole.

- **GN 322-A:** without handle.
- **GN 322-R:** with revolving handle in polyamide based (PA) technopolymer, black colour, matte finish.
- **GN 322.3:** with fold-away handle in polyamide based (PA) technopolymer, black colour, matte finish.

**SPECIAL EXECUTIONS ON REQUEST**

- Handwheels with safety GN 000.5 (see page 160).
- GN 324 handwheels with black epoxy resin coating, matte finish.
- GN 322.7 handwheels with automatic fold-away safety handle.
- keyway in compliance with DIN 6885/1 tolerance P9 (see page A-15).

**TECHNICAL DATA**

Axial and radial runout lower than IT 12.

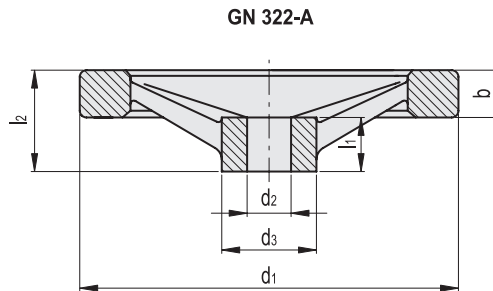

**Conversion Table**  
1 mm = 0.039 inch

d1	
mm	inch
125	4.92
140	5.51
160	6.30
200	7.87
250	9.84

**GN 322-A**

METRIC

Code	Description	d1	d2 H7	d3	b	l1	l2	⚖
GN.26101	GN 322-125-B12-A	125	12	31	15	18	33	311
GN.26103	GN 322-125-B14-A	125	14	31	15	18	33	308
GN.26111	GN 322-140-B14-A	140	14	36	16.5	19	36	411
GN.26113	GN 322-140-B16-A	140	16	36	16.5	19	36	394
GN.26120	GN 322-160-B14-A	160	14	36	18	20	39	539
GN.26121	GN 322-160-B16-A	160	16	36	18	20	39	530
GN.26131	GN 322-200-B18-A	200	18	42	20.5	24	45	892
GN.26133	GN 322-200-B20-A	200	20	42	20.5	24	45	885
GN.26141	GN 322-250-B22-A	250	22	48	23	28	51	1478
GN.26143	GN 322-250-B26-A	250	26	48	23	28	51	1454

Operating elements

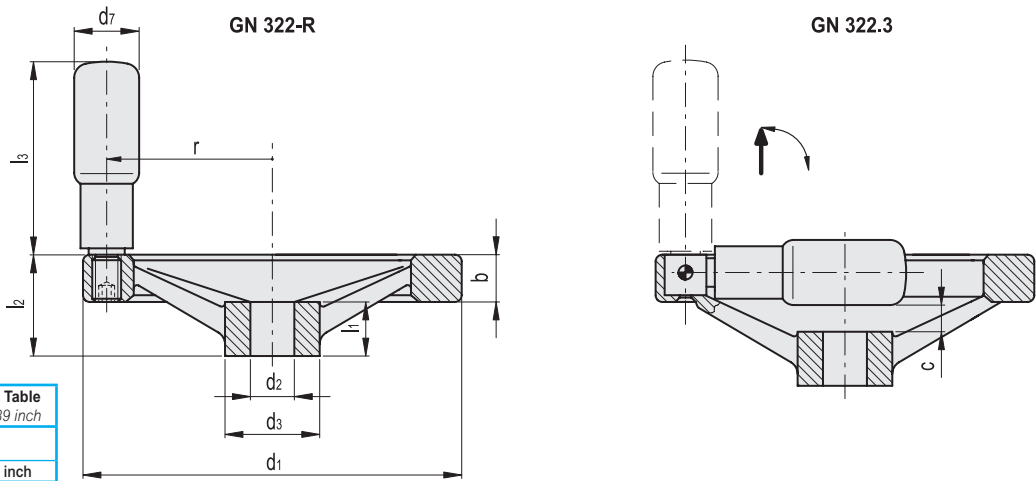

Conversion Table	
1 mm = 0.039 inch	
d1	
mm	inch
125	4.92
140	5.51
160	6.30
200	7.87
250	9.84

GN 322-R

METRIC

Code	Description	d1	d2 H7	d3	b	l1	l2	l3	r	d7	⚖
GN.26105	GN 322-125-B12-R	125	12	31	15	18	33	61.5	54	22	383
GN.26107	GN 322-125-B14-R	125	14	31	15	18	33	61.5	54	22	386
GN.26115	GN 322-140-B14-R	140	14	36	16.5	19	36	76.5	61	24	486
GN.26117	GN 322-140-B16-R	140	16	36	16.5	19	36	76.5	61	24	469
GN.26123	GN 322-160-B14-R	160	14	36	18	20	39	76.5	71	24	643
GN.26125	GN 322-160-B16-R	160	16	36	18	20	39	76.5	71	24	634
GN.26135	GN 322-200-B18-R	200	18	42	20.5	24	45	86.5	89	25	996
GN.26137	GN 322-200-B20-R	200	20	42	20.5	24	45	86.5	89	25	989
GN.26145	GN 322-250-B22-R	250	22	48	23	28	51	86.5	113	25	1598
GN.26147	GN 322-250-B26-R	250	26	48	23	28	51	86.5	113	25	1574

GN 322.3

Code	Description	d1	d2 H7	d3	b	l1	l2	l3	c	r	d7	⚖
GN.26205	GN 322.3-125-B12-R	125	12	31	24.5	18	44	60	6.5	50	22	469
GN.26225	GN 322.3-160-B14-R	160	14	36	25	20	47	75	6.5	67.5	24	697
GN.26235	GN 322.3-200-B18-R	200	18	42	25	24	52.5	85	7.5	84	25	978
GN.26245	GN 322.3-250-B22-R	250	22	48	26.5	28	61	85	12	111	25	1388

- 1
- 2
- 3
- 4
- 5
- 6
- 7
- 8
- 9
- 10
- 11
- 12
- 13
- 14
- 15
- 16
- 17
- 18

Operating elements